

LOW- Δ P-FLOW

Mass Flow Meters/Controllers for
low pressure drop or corrosive gas service

> Introduction

Bronkhorst High-Tech B.V., the European market leader in thermal Mass Flow Meters/Controllers and Electronic Pressure Controllers, has more than 25 years experience in designing and manufacturing precise and reliable measurement and control devices. With a wide range of instruments, Bronkhorst High-Tech offers innovative solutions for many different applications in many different markets. The instruments are made to customers' specification, in various styles, suitable for use in laboratory, industrial and hazardous areas, in such diverse applications as semiconductor and analytical installations, to name but two.

> LOW- Δ P-FLOW series for low pressure drop or corrosive gases

In a number of applications for measuring and controlling gas flows there is only little differential pressure available and/or allowable. These are the applications for which Bronkhorst High-Tech developed the LOW- Δ P-FLOW series, in which the flow resistance is minimised by using a large bore capillary (thermal bypass sensor) in combination with a cylindrical flow splitter (laminar flow element). Based on this concept, mass flow capacities between 0...10 ml_n/min and 0...1000 m³_n/h can be measured. At a flow up to 2 l_n/min a pressure drop of less than 1 mbar is required.

Furthermore the larger flow channels minimise the risk of clogging and facilitate the cleaning and purging of these LOW- Δ P-FLOW instruments, which will contribute to a significantly longer lifetime when the instruments are used on corrosive gas service. All fluid wetted parts are of electro-polished stainless steel. Optionally the flow meter body, sensor and flow element can be supplied in Hastelloy or Monel.

> For laboratory or industrial conditions

The LOW- Δ P-FLOW series are derived from the laboratory style EL-FLOW series, however they can also be supplied with a rugged IP65 (dust and waterproof) IN-FLOW housing, suitable for industrial environments. The latter are also ATEX Category 3, approved for use in Zone 2 hazardous areas. In addition to the standard analog I/O-signals and the RS232 connection, there is the possibility of integrating an interface board with DeviceNet™, Profibus-DP®, Modbus-RTU or FLOW-BUS protocol.



> Mass flow control with low differential pressure

The control of mass flow with small pressure difference comprises the LOW- Δ P-FLOW Mass Flow Controllers in compact construction (model series F-200/201/202). The integrated proportional, electro-magnetic control valves of these MFC's have extremely fast and smooth control characteristics. Depending on the operating properties, the maximum flow in these models is 1...50 l_n/min air-equivalent.

For the control of higher flow rates at very low differential pressures Bronkhorst High-Tech have devised special control valves with pressure compensation bellows (series F-004). These control valves are close-coupled to the flow meter while the electric PI-control function is an integral part of the flow meter. This F-004 valve has proven to be an excellent alternative to large, slow and expensive servo driven valves.

> LOW- Δ P-FLOW features

- ◆ very low pressure drop
- ◆ suitable for corrosive gases
- ◆ wetted parts: electro-polished stainless steel; other on request
- ◆ also available with IP65 housing, ATEX approval Cat.3, Zone 2
- ◆ analog and digital (fieldbus) communication
- ◆ alarm and counter functions



Bronkhorst[®]
HIGH-TECH

> Technical specifications

Measurement / control system

Accuracy (incl. linearity)	: ± 1% FS (of Full Scale)
Turndown	: 1 : 50 (2 ... 100%)
Repeatability	: < 0,2% Rd (of Reading)
Settling time (controller)	: standard: 2...3 seconds
Control stability	: < ±0,1% FS (typical for 1 l _n /min N2)
Operating temperature	: -10...+70°C
Max. operating pressure	: 10 bar
Temperature sensitivity	: 0,1% FS/°C; for ATEX Cat.3 max. 50°C
Pressure sensitivity	: 0,1%/bar typical N2
Leak integrity	: tested < 2 x 10 ⁻⁹ mbar l/s He
Mounting position	: horizontal
Warm-up time	: 30 min. for optimum accuracy; 2 min for accuracy ± 2% FS

Mechanical parts

Material (wetted parts)	: stainless steel, other on request
Process connections	: compression type or face seal couplings; wafer type on series F-106; DIN or ANSI flanges on series F-107
Seals	: standard: Viton options: EPDM, Kalrez (FFKM)
Ingress protection (housing)	: IP40 or IP65

Electrical properties

Power supply	: +15...24 Vdc
Power consumption	: meter: 70 mA; controller: max. 320 mA; add 50 mA for Profibus, if applicable
Analog output/command	: 0...5 (10) Vdc or 0 (4)...20 mA (sourcing output)
Digital communication	: standard: RS232 options: Profibus-DP®, DeviceNet™, Modbus-RTU, FLOW-BUS

Electrical connection IP40 configuration

Analog/RS232	: 9-pin D-connector (male);
Profibus-DP	: bus: 9-pin D-connector (female); power: 9-pin D-connector (male);
DeviceNet™	: 5-pin M12-connector (male);
Modbus-RTU/FLOW-BUS	: RJ45 modular jack

Electrical connection IP65 configuration

Analog/RS232	: 8 DIN (male);
Profibus-DP®	: bus: 5-pin M12 (female); power: 8 DIN (male)
DeviceNet™	: 5-pin M12 (male)
Modbus-RTU/FLOW-BUS	: 5-pin M12 (male)

Technical specifications subject to change without notice.

> Models and flow ranges (based on Air)

Mass Flow Meters (MFM)

Model	min. flow	max. flow
F-100D/F-100DI	0,2...10 ml _n /min	0,44...22 ml _n /min
F-101D/F-101DI	0,42...21 ml _n /min	0,042...2,1 l _n /min
F-101E/F-101EI	0,028...1,4 l _n /min	0,24...12 l _n /min
F-102E/F-102EI	0,17...8,5 l _n /min	1...50 l _n /min
F-103E/F-103EI	0,9...45 l _n /min	4...200 l _n /min
F-106Z/F-107Z	0,2...10 m ³ _n /h	20...1000 m ³ _n /h

Mass Flow Controllers (MFC)

Model	min. flow	max. flow
F-200D/F-200DI ¹⁾	0,2...10 ml _n /min	0,44...22 ml _n /min
F-201D/F-201DI ¹⁾	0,42...21 ml _n /min	0,042...2,1 l _n /min
F-201E/F-201EI ¹⁾	0,028...1,4 l _n /min	0,24...12 l _n /min
F-202E/F-202EI ¹⁾	0,17...8,5 l _n /min	1...50 l _n /min

¹⁾ Kv-max = 6,6 x 10⁻²

Control Valve series F-004

	F-004AC/F-004AI	F-004BI
Kv-value	0,3	1,0
Max. operating pressure	10 bara	10 bara
Min. ΔP (approx.)	1 mbard	1 mbard
Max. ΔP	5 bard	5 bard
Max. power (at 15 Vdc)	3,5 Watt	3,5 Watt
Protection class	F-004AC: IP40 F-004AI: IP65	IP65



Models F-004BI and F-004AC bellows operated control valves

> Conversion factor calculations for model selection

To select the right model for other gases than Air, we have to carry out two calculations:

$$1. \quad \varnothing_{vn} \text{ Air} = \frac{\varnothing_{vn} \text{ gas}}{\text{conversion factor}}$$

$$2. \quad \varnothing_{vn} \text{ Air} = \frac{\varnothing_{vn} \text{ gas}}{\text{viscosity factor}}$$

The highest flow rate calculated determines the flow capacity.

Example: Freon-22, 1 l_r/min

Conversion factor = 0,47 (see table below)

Viscosity factor = 0,31 (see table below)

$$1. \quad \varnothing_{vn} \text{ Air} = 1/0,47 = 2,13 \text{ l}_r/\text{min}$$

$$2. \quad \varnothing_{vn} \text{ Air} = 1/0,31 = 3,23 \text{ l}_r/\text{min}$$

Highest flow rate = 3,23 l_r/min so we can select model F-101E or F-101EI MFM resp. F-201EV or F-201EI MFC.



F-201EI LOW-ΔP-FLOW Mass Flow Controller. IP65 configuration

> Conversion factors and viscosity factors

Name	A	B	C	Name	A	B	C	Name	A	B	C
Acetylene (Ethyne)	C ₂ H ₂	0,61	0,61	Ethylene (Ethene)	C ₂ H ₄	0,60	0,58	Methylacetylene	C ₃ H ₄	0,43	0,36
Air	Air	1,00	1,00	Ethylene oxide	C ₂ H ₄ O	0,52	0,41	Methylbromide	CH ₃ BR	0,61	0,33
Allene (Propadiene)	C ₃ H ₄	0,43	0,36	Ethylacetylene (1-Butyne)	C ₄ H ₆	0,32	0,26	Methylchloride	CH ₃ Cl	0,64	0,44
Ammonia	NH ₃	0,77	0,86	Ethylchloride	C ₂ H ₅ Cl	0,41	0,29	Methylfluoride	CH ₃ F	0,70	0,68
Argon	Ar	1,40	1,08	Fluorine	F ₂	0,91	0,96	Methylmercaptan	CH ₃ SH	0,53	0,39
Arsine	AsH ₃	0,66	0,42	Freon-11	CCl ₃ F	0,35	0,18	Mono-ethylamine	C ₂ H ₅ NH ₂	0,36	0,30
Boron trichloride	BCl ₃	0,44	0,23	Freon-113	C ₂ Cl ₃ F ₃	0,21	0,13	Monomethylamine	CH ₃ NH ₂	0,52	0,44
Boron trifluoride	BF ₃	0,54	0,44	Freon-1132A	C ₂ H ₂ F ₂	0,44	0,37	Neon	Ne	1,41	1,86
Bromine pentafluoride	BrF ₅	0,26	0,20	Freon-114	C ₂ Cl ₂ F ₄	0,23	0,15	Nitric oxide	NO	0,97	0,98
Butadiene (1,3-)	C ₄ H ₆	0,31	0,25	Freon-115	C ₂ ClF ₅	0,24	0,17	Nitrogen	N ₂	1,00	1,00
Butane	C ₄ H ₁₀	0,25	0,21	Freon-116	C ₂ F ₆	0,25	0,20	Nitrogen dioxide	NO ₂	0,74	0,55
Butene (1-)	C ₄ H ₈	0,29	0,24	Freon-12	CCl ₂ F ₂	0,37	0,22	Nitrogen trifluoride	NF ₃	0,50	0,43
Butene (2-) (Cis)	C ₄ H ₈	0,32	0,25	Freon-13	CClF ₃	0,40	0,28	Nitrosyl chloride	NOCl	0,61	0,38
Butene (2-) (Trans)	C ₄ H ₈	0,30	0,24	Freon-13B1	CBR ₃	0,38	0,23	Nitrous oxide	N ₂ O	0,71	0,59
Carbonylfluoride	COF ₂	0,54	0,46	Freon-14	CF ₄	0,44	0,37	Oxygen	O ₂	0,98	1,00
Carbonylsulfide	COS	0,65	0,43	Freon-21	CHCl ₂ F	0,44	0,25	Oxygen difluoride	OF ₂	0,64	0,58
Carbon dioxide	CO ₂	0,74	0,60	Freon-22	CHClF ₂	0,47	0,31	Ozone	O ₃	0,70	0,56
Carbon disulfide	CS ₂	0,60	0,31	Freon-23	CHF ₃	0,52	0,39	Pentane	C ₅ H ₁₂	0,21	0,15
Carbon monoxide	CO	1,00	0,97	Freon-C318	C ₄ F ₈	0,15	0,15	Perchlorylfluoride	ClO ₃ F	0,41	0,29
Chlorine	Cl ₂	0,82	0,45	Helium	He	1,41	3,36	Perfluoropropane	C ₃ F ₈	0,16	0,13
Chlorine trifluoride	ClF ₃	0,40	0,29	Helium (3-)	3He	1,44	3,91	Performa-ethylene	C ₂ F ₄	0,33	0,26
Cyanogen	C ₂ N ₂	0,48	0,35	Hydrogen	H ₂	1,01	2,66	Phosgene	COCl ₂	0,47	0,27
Cyanogen chloride	CICN	0,61	0,42	Hydrogen bromide	HBr	0,98	0,53	Phosphine	PH ₃	0,73	0,60
Cyclopropane	C ₃ H ₆	0,43	0,36	Hydrogen chloride	HCl	0,99	0,77	Propane	C ₃ H ₈	0,34	0,31
Deuterium	D ₂	1,00	2,14	Hydrogen cyanide	HCN	0,75	0,53	Propylene (Propene)	C ₃ H ₆	0,40	0,35
Diborane	B ₂ H ₆	0,43	0,43	Hydrogen fluoride	HF	0,96	0,95	Silane	SiH ₄	0,62	0,59
Dibromo difluoromethane	Br ₂ CF ₂	0,20	0,13	Hydrogen iodide	HI	0,79	0,40	Sulfur dioxide	SO ₂	0,68	0,43
Dichlorosilane	SiH ₂ Cl ₂	0,41	0,31	Hydrogen selenide	H ₂ Se	0,78	0,45	Sulfur hexafluoride	SF ₆	0,27	0,20
Dimethylamine	C ₂ H ₆ NH	0,37	0,31	Hydrogen sulfide	H ₂ S	0,82	0,64	Trimethylamine	C ₃ H ₉ N	0,28	0,23
Dimethylpropane (2,2-)	C ₅ H ₁₂	0,21	0,18	Isobutane	C ₄ H ₁₀	0,25	0,22	Tungsten hexafluoride	WF ₆	0,25	0,14
Dimethylether	C ₂ H ₆ O	0,39	0,33	Isobutylene (isobutene)	C ₄ H ₈	0,28	0,23	Vinylchloride	C ₂ H ₃ Cl	0,47	0,33
Disilane	Si ₂ H ₆	0,31	0,35	Krypton	Kr	1,43	0,75	Vinylfluoride	C ₂ H ₃ F	0,49	0,43
Ethane	C ₂ H ₆	0,49	0,49	Methane	CH ₄	0,76	0,91	Xenon	Xe	1,38	0,54

A = Symbol - B = conversion factor @ 20°C, 1 atm. - C = viscosity factor @ 20°C, 1 atm.

> Dimensions (mm)

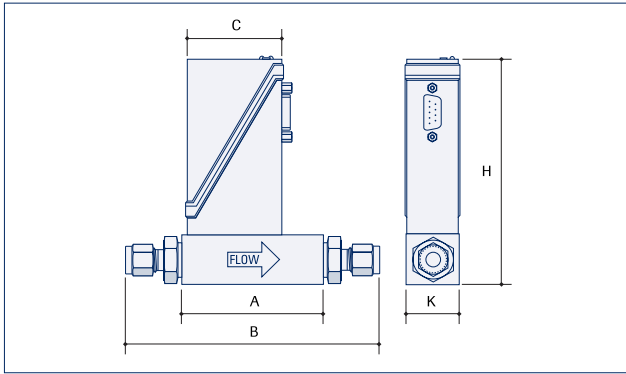

IP40 Mass Flow Meter

Model	A	B	C	H	K	Weight (kg)
F-100D (1/8")	47	98	47	111	25	0,4
F-101D/F-101E (1/4")	69	126	47	111	25	0,5
F-102E (1/2")	69	134	47	123	26	0,6
F-103E (1/2")	110	177	47	168	89	4,0

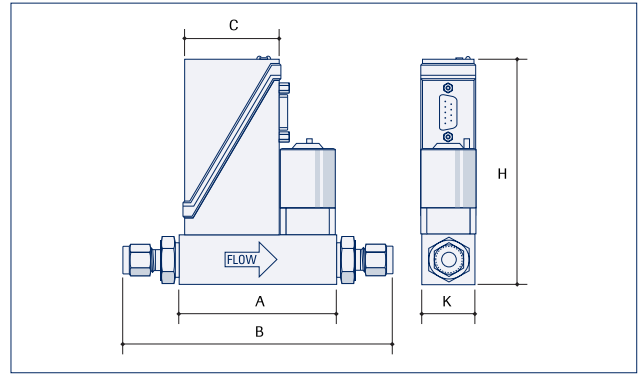

IP40 Mass Flow Controller

Model	A	B	C	H	K	Weight (kg)
F-200DV (1/8")	77	128	47	111	25	0,6
F-201DV/F-201EV (1/4")	77	134	47	111	25	0,6
F-202EV (1/2")	78	143	47	123	26	0,8

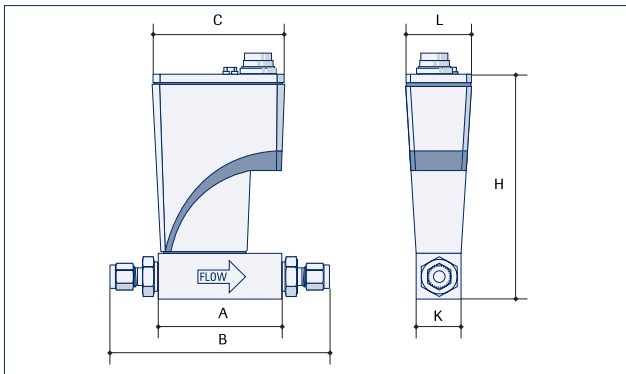

IP65 Mass Flow Meter, low/medium flow

Model	A	B	C	H	K	L	Weight (kg)
F-100DI (1/8")	47	98	74	125	25	36	0,8
F-101DI/F-101EI (1/4")	69	126	74	125	25	36	0,9
F-102EI (1/2")	69	134	74	137	26	36	1,0
F-103EI (1/2")	110	177	74	182	89	36	4,4

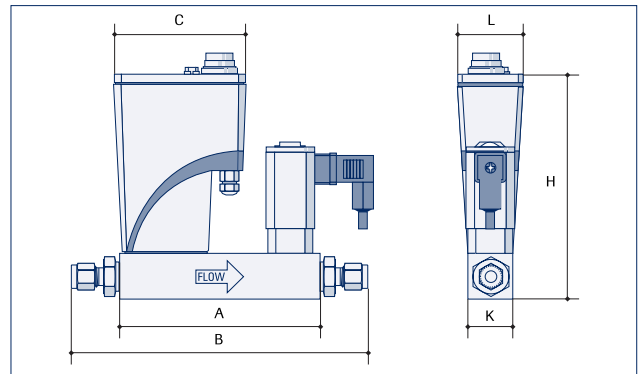

IP65 Mass Flow Controller

Model	A	B	C	H	K	L	Weight (kg)
F-200DI (1/8")	112	164	74	125	25	36	1,3
F-201DI/F-201EI (1/4")	112	169	74	125	25	36	1,3
F-202EI (1/2")	112	169	74	139	59	36	1,5

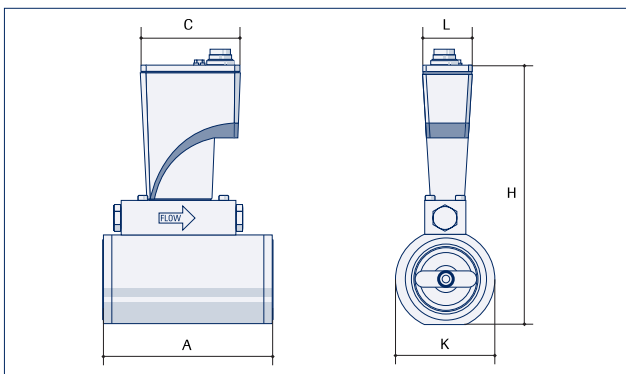

IP65 Mass Flow Meter, high flow, wafer type

Model	A	C	H	K	L	Weight (kg)
F-106AZ	125	74	111	75	192	4,0
F-106BZ	125	74	111	85	205	4,6
F-106CZ	125	74	123	115	234	6,8
F-106DZ	125	74	139	145	264	9,5
F-106EZ	125	74	139	198	319	13,3

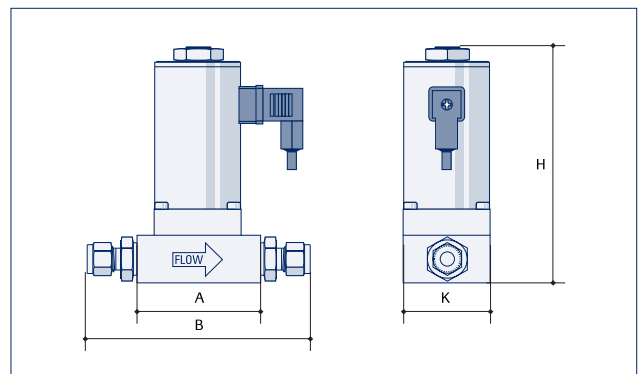

F-004 series Control Valves

Model	A	B	H	K	Weight (kg)
F-004AC/AI (1/4")	64	121	122	45	1,2
F-004BI (1/2")	85	152	174	65	3,4

Dimensions subject to change without notice. For certified drawings and for dimensions of F-107Z series flanged type mass flow meters please contact factory.

> Ranges and pressure drop Mass Flow Meters

Model	Flow ml _n /min Air	ΔP (mbar) at atm.	
		1/8" tube	1/4" tube
F-100D/F-100DI	10	0.8	0.8
F-100D/F-100DI	15	0.8	0.8
F-101D/F-101DI	20	0.8	0.8
F-101D/F-101DI	50	0.8	0.8
F-101D/F-101DI	100	0.8	0.8
F-101D/F-101DI	200	0.8	0.8
F-101D/F-101DI	500	0.8	0.8
F-101D/F-101DI	1000	0.8	0.8
F-101D/F-101DI	2000	-	0.8

Model	Flow l _n /min Air	ΔP (mbar) at atm.	
		1/4" tube	1/2" tube
F-101E/F-101EI	5	5,5	5
F-101E/F-101EI	10	6	5,5
F-102E/F-102EI	20	8,5	6,5
F-102E/F-102EI	50	-	15

Model	Flow l _n /min Air	ΔP (mbar) at atm.	
		1/2" tube	3/4" tube
F-103E/F-103EI	100	-	8
F-103E/F-103EI	200	-	15

Model	Size		Flow m ³ _n /h Air	ΔP(mbar) at atm.
	DIN	ANSI		
F-106AZ/F-107AZ	DN40	1 1/2"	10	7
F-106AZ/F-107AZ	DN40	1 1/2"	20	13
F-106AZ/F-107AZ	DN40	1 1/2"	50	35
F-106BZ/F-107BZ	DN50	2"	20	7
F-106BZ/F-107BZ	DN50	2"	50	18
F-106BZ/F-107BZ	DN50	2"	100	39
F-106CZ/F-107CZ	DN80	3"	50	7
F-106CZ/F-107CZ	DN80	3"	100	15
F-106CZ/F-107CZ	DN80	3"	200	32
F-106DZ/F-107DZ	DN100	4"	100	9
F-106DZ/F-107DZ	DN100	4"	200	17
F-106DZ/F-107DZ	DN100	4"	500	48
F-106EZ/F-107EZ	DN150	6"	200	7
F-106EZ/F-107EZ	DN150	6"	500	19
F-106EZ/F-107EZ	DN150	6"	1000	41



> Fields of application

The LOW-ΔP-FLOW series have been successfully applied in a wide variety of both OEM and laboratory applications, e.g.:

- ◆ Environmental air sampling at atmospheric conditions
- ◆ Leak rate and permeability measurements
- ◆ Burner control
- ◆ Measurement of gas consumption, for example of natural gas, in low pressure gas distribution systems

> Air sampling

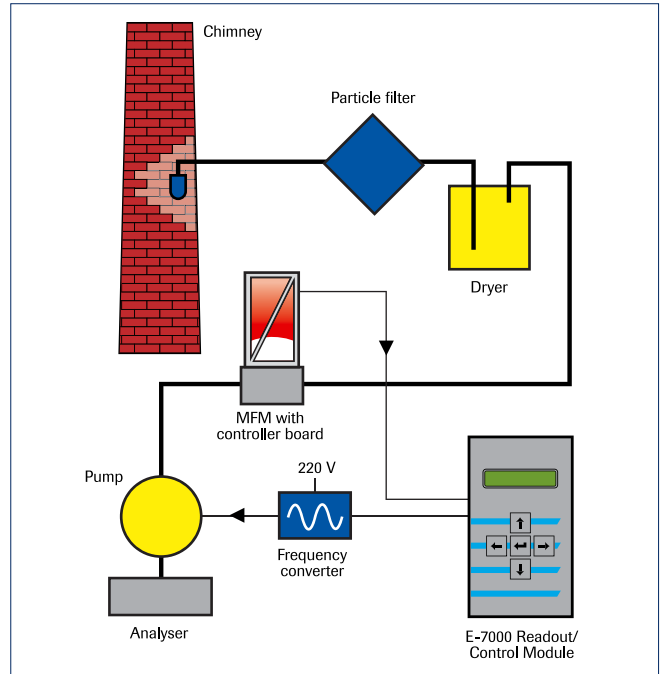

An interesting example to control a flow rate is using a LOW-ΔP-FLOW Mass Flow Meter in combination with a sampling pump. In this configuration the speed of the pump is controlled to obtain the required mass flow rate, determined by the setpoint value.

> Burner control

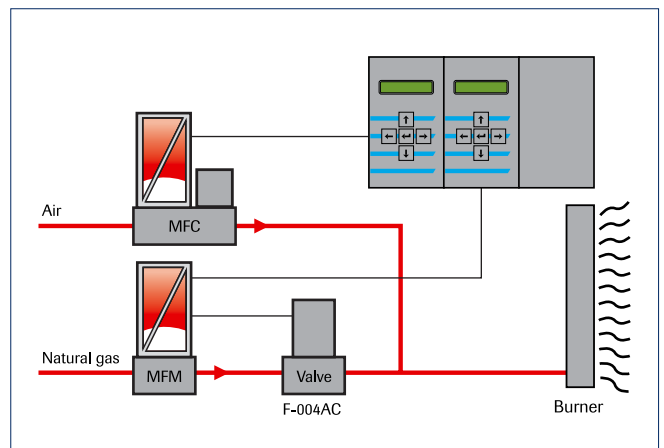

Burner control using Mass Flow Controllers brings many advantages compared to conventional systems, where flow is adjusted through needle valves. When burner orifices get clogged or when gas supply pressure varies, an MFC will automatically adapt to the changed conditions. For the control of relatively large flows with low differential pressure, which is typical for natural gas or CH₄, LOW-ΔP-FLOW Mass Flow Meters in combination with F-004 pressure compensated bellows valves have proven to be a successful solution.

> Model number identification

F - N N NAA - A A A - NN - A

Base

0	Valve only
1	Meter
2	Controller

Pressure rating

0	64 bar
---	--------

Ranges

See page 2 of this leaflet,
"Models and flow ranges"

Communication (I/O)

A	RS232 + analog (n/c control)
B	RS232 + analog (n/o control)
D	RS232 + DeviceNet™ (n/c control)
E	RS232 + DeviceNet™ (n/o control)
M	RS232 + Modbus-RTU (n/c control)
N	RS232 + Modbus-RTU (n/o control)
P	RS232 + Profibus-DP® (n/c control)
Q	RS232 + Profibus-DP® (n/o control)
R	RS232 + FLOW-BUS (n/c control)
S	RS232 + FLOW-BUS (n/o control)

Analog output

A	0...5 Vdc
B	0...10 Vdc
F	0...20 mA sourcing
G	4...20 mA sourcing

Supply voltage

B	+24 Vdc (DeviceNet™)
D	+15...24 Vdc (analog, FLOW-BUS, Profibus-DP®, Modbus-RTU)

Connections (in/out)

compression type couplings

11	1/8"	OD compression type
22	1/4"	OD compression type
33	6 mm	OD compression type
44	12 mm	OD compression type
55	1/2"	OD compression type
66	20 mm	OD compression type
88	1/4"	Face seal male
99	other	

mounting between flanges

01	mounting betw. flange, DIN PN10
02	mounting betw. flange, DIN PN16
03	mounting betw. flange, DIN PN40
06	mounting betw. flange, ANSI 150
07	mounting betw. flange, ANSI 300
13	Flanged connection, DIN PN40
26	Flanged connection, ANSI 150
99	other

Internal seals

V	Viton (factory standard)
E	EPDM
K	Kalrez (FFKM)



F-101DI Mass Flow Meter, IP65 configuration



F-102E Mass Flow Meter, IP40 configuration

Bronkhorst®
HIGH-TECH